

ORDERING INFORMATION

Device	Temperature Range	Package
MC1550F	-55°C to +125°C	Ceramic Flat
MC1550G	-55°C to +125°C	Metal Can

MC1550G

**RF - IF AMPLIFIER
SILICON MONOLITHIC
INTEGRATED CIRCUIT**

RF - IF AMPLIFIER

... a versatile, common-emitter, common-base cascode circuit for use in communications applications. See Application Note AN-215A for additional information.

- Constant Input Impedance over entire AGC range
- Extremely Low γ_{12} - 4.3 μmhos at 60 MHz
- High Power Gain - 30 dB @ 60 MHz (0.5 MHz BW)
- Good Noise Figure - 5 dB @ 60 MHz



**G SUFFIX
METAL PACKAGE
CASE 603B**

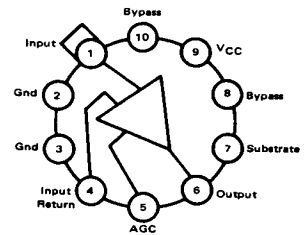

MAXIMUM RATINGS ($T_A = +25^\circ\text{C}$ unless otherwise noted)

Rating	Symbol	Value	Unit
Power Supply Voltage, Pin 9	V_{CC}	20	Vdc
AGC Supply Voltage	V_{AGC}	20	Vdc
Input Differential Voltage, Pin 1 to Pin 4 ($R_S = 500$ ohms)	V_{ID}	± 5.0	V(rms)
Power Dissipation (Package Limitation)	P_D		
Metal Can		680	mW
Derate above $T_A = +25^\circ\text{C}$		4.6	$\text{mW}/^\circ\text{C}$
Flat Package		500	mW
Derate above $T_A = +25^\circ\text{C}$		3.3	$\text{mW}/^\circ\text{C}$
Operating Ambient Temperature Range	T_A	-55 to +125	$^\circ\text{C}$
Storage Temperature Range	T_{stg}	-65 to +150	$^\circ\text{C}$

6

CIRCUIT SCHEMATIC

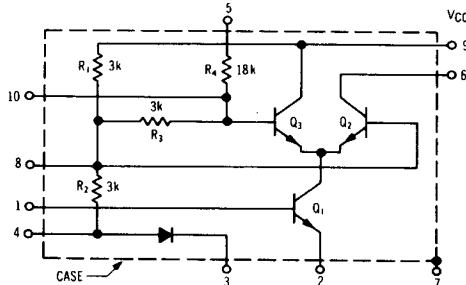

CIRCUIT DESCRIPTION

The MC1550 is built with monolithic fabrication techniques utilizing diffused resistors and small-geometry transistors. Excellent AGC performance is obtained by shunting the signal through the AGC transistor Q_3 , maintaining the operating point of the input transistor Q_1 . This keeps the input impedance constant over the entire AGC range.

The amplifier is intended to be used in a common-emitter, common-base configuration (Q_1 and Q_2) with Q_3 acting as an AGC transistor. The input signal is applied between pins 1 and 4, where pin 4 is ac-coupled to ground. DC source resistance between pins 1 and 4 should be small (less than 100 ohms). Pins 2 and 3 should be connected together and grounded. Pins 8 and 10 should be bypassed to ground. The positive supply voltage is applied at pin 9 and at higher frequencies, pin 9 should also be bypassed to ground. The output is taken between pins 6 and 9. The substrate is connected to pin 7 and should be grounded. AGC voltage is applied to pin 5.

ELECTRICAL CHARACTERISTICS ($V^+ = +6 \text{ Vdc}$, $T_A = +25^\circ\text{C}$)

Characteristic	Conditions	Figure	Symbol	Min	Typ	Max	Unit
DC CHARACTERISTICS							
Output Voltage	$V_{AGC} = 0 \text{ Vdc}$ $V_{AGC} = +6 \text{ Vdc}$	1	V_O	3.80 5.90	— —	4.65 6.00	Vdc
Test Voltage	$V_{AGC} = 0 \text{ Vdc}$ $V_{AGC} = +6 \text{ Vdc}$	1	V_8	2.85 3.25	— —	3.40 3.80	Vdc
Supply Drain Current	$V_{AGC} = 0 \text{ Vdc}$ $V_{AGC} = +6 \text{ Vdc}$	1	I_D	— —	— —	2.2 2.5	mAdc
AGC Supply Drain Current	$V_{AGC} = 0 \text{ Vdc}$ $V_{AGC} = +6 \text{ Vdc}$	1	I_{AGC}	— —	— —	-0.2 0.18	mAdc
SMALL-SIGNAL CHARACTERISTICS							
Small-Signal Voltage Gain	$f = 500 \text{ kHz}$	2	A_V	22	—	29	dB
Bandwidth	-3.0 dB	2	BW	22	—	—	MHz
Transducer Power Gain	$f = 60 \text{ MHz}$, BW = 6 MHz $f = 100 \text{ MHz}$, BW = 6 MHz	3	A_p	—	25 21	— —	dB

TYPICAL CHARACTERISTICS
($V_{CC} = 6.0 \text{ Vdc}$, $T_A = +25^\circ\text{C}$ unless otherwise noted.)

FIGURE 1 – DC CHARACTERISTICS TEST CIRCUIT

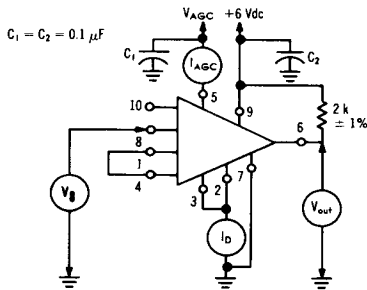

FIGURE 2 – VOLTAGE GAIN AND BANDWIDTH TEST CIRCUIT

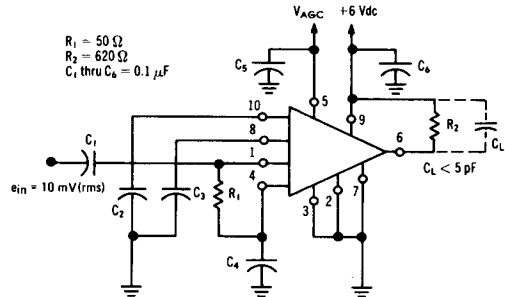

FIGURE 3 – POWER GAIN TEST CIRCUIT @ 60 MHz

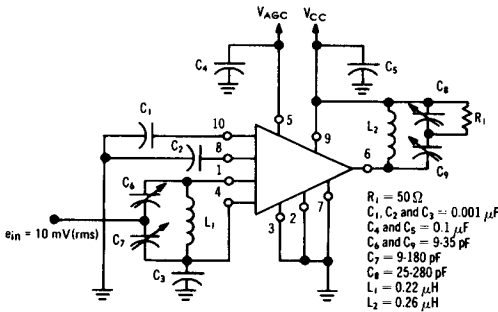
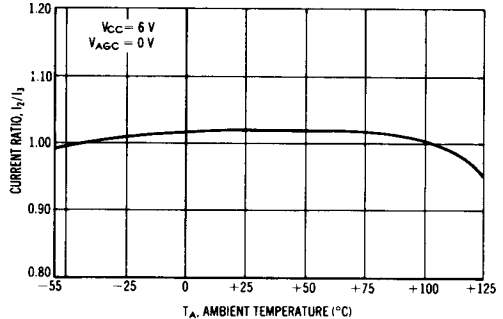

FIGURE 4 – DRAIN CURRENT TEMPERATURE CHARACTERISTICS



TYPICAL CHARACTERISTICS (continued)

FIGURE 5 – INPUT RESISTANCE AND CAPACITANCE versus FREQUENCY

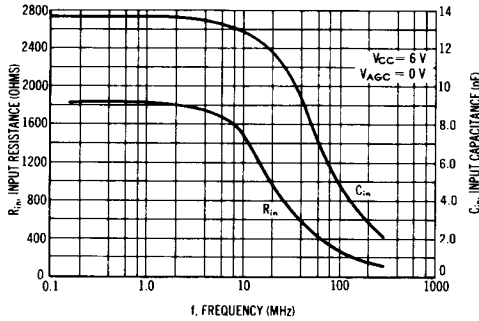

FIGURE 6 – INPUT RESISTANCE AND CAPACITANCE versus AGC VOLTAGE

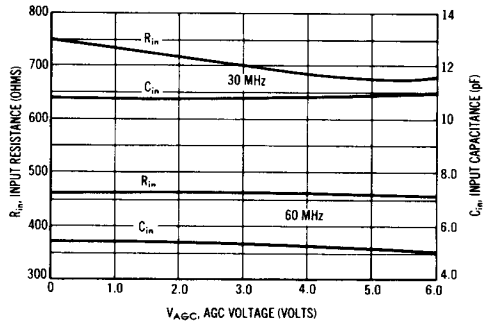

FIGURE 7 – OUTPUT RESISTANCE AND CAPACITANCE versus FREQUENCY

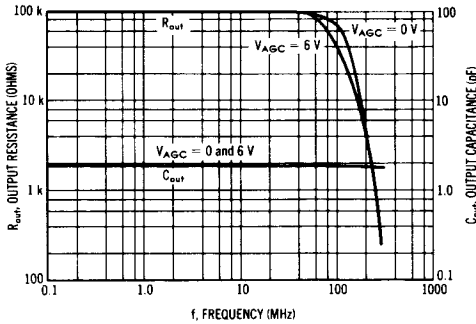

FIGURE 8 – OUTPUT RESISTANCE AND CAPACITANCE versus AGC VOLTAGE

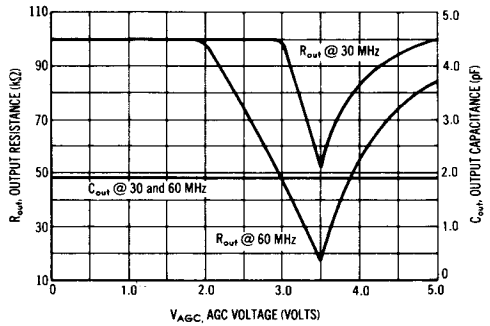

FIGURE 9 – MAXIMUM TRANSDUCER POWER GAIN versus FREQUENCY

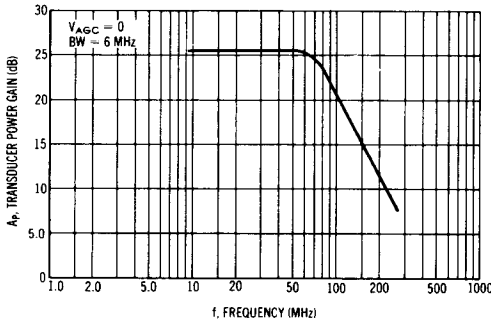
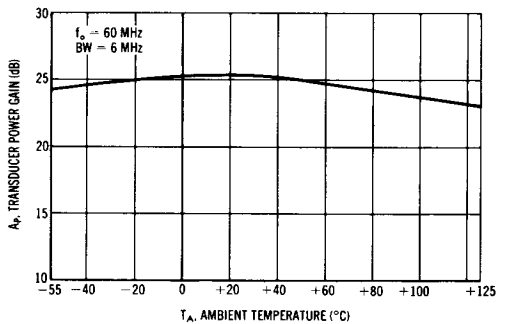

FIGURE 10 – TRANSDUCER POWER GAIN versus TEMPERATURE



6

TYPICAL CHARACTERISTICS (continued)

FIGURE 11 – TRANSDUCER POWER BANDWIDTH versus AGC VOLTAGE

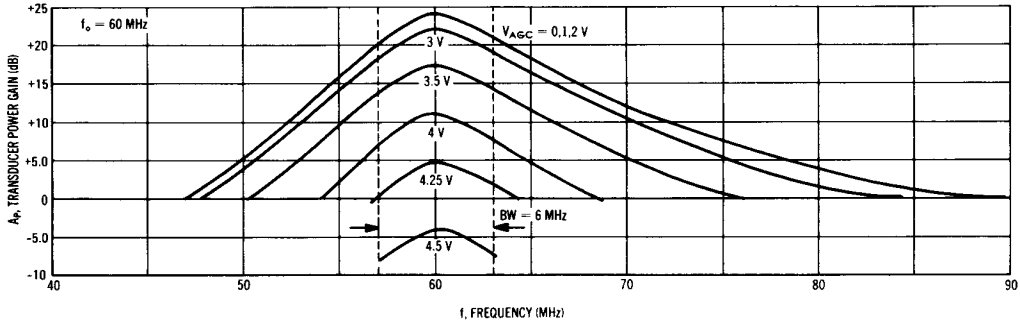

FIGURE 12 – NOISE FIGURE AND OPTIMUM SOURCE RESISTANCE versus FREQUENCY

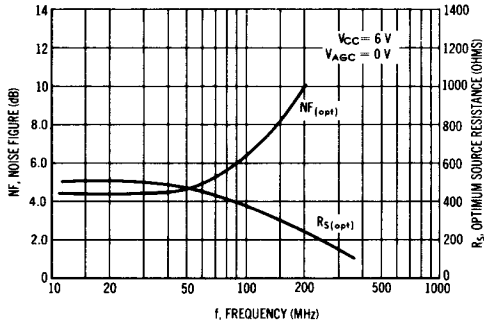

FIGURE 13 – NOISE FIGURE versus SOURCE RESISTANCE

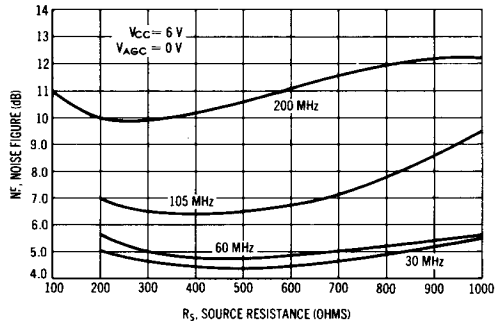

FIGURE 14 – y_{21} , FORWARD-TRANSFER ADMITTANCE versus FREQUENCY

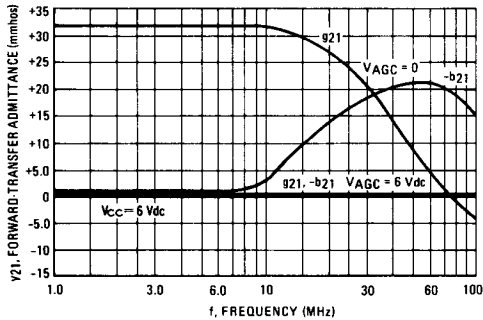
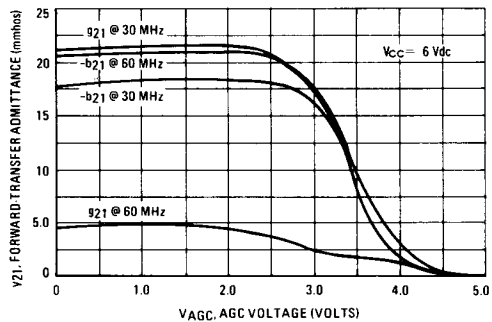

FIGURE 15 – y_{21} , FORWARD-TRANSFER ADMITTANCE versus AGC VOLTAGE



TYPICAL CHARACTERISTICS

($V_{CC} = 6.0 \text{ Vdc}$, $T_A = +25^\circ\text{C}$ unless otherwise noted.)

FIGURE 16 — y_{12} , REVERSE TRANSFER-ADMITTANCE versus FREQUENCY

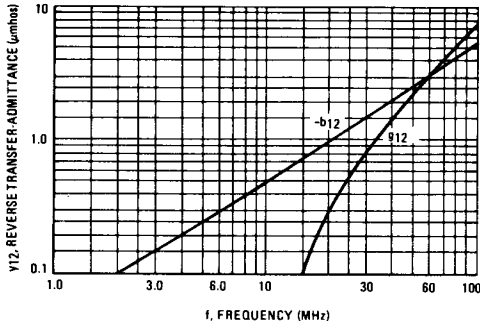

FIGURE 17 — y_{11} , INPUT-ADMITTANCE versus FREQUENCY

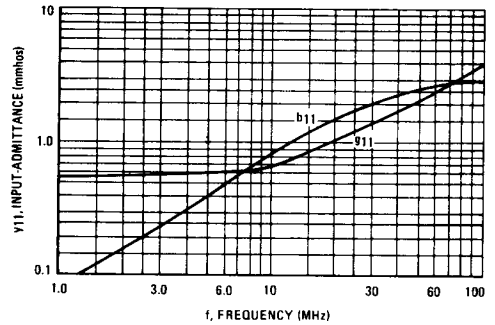
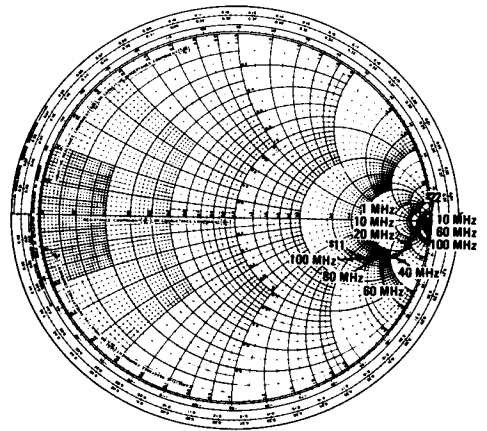

FIGURE 19 — s_{11} AND s_{22} , INPUT AND OUTPUT REFLECTION COEFFICIENT



The y_{12} shown in Figure 16 illustrates the extremely low feedback of the MC1550 with no contribution from the external mounting circuitry. However, in many cases the external circuitry may contribute as much or more to the total feedback than does the MC1550.

To perform more accurate design calculations of gain, stability, and input - output impedances it is recommended that the designer first determine the total feedback of device plus circuitry.

This can be done in one of two ways:

- (1) Measure the total y_{12} or s_{12} of the MC1550 installed in its mounting circuitry, or
- (2) Measure the y_{12} of the circuitry alone (without the MC1550 installed) and add the circuit y_{12} to the y_{12} for the MC1550 given in Figure 16.

FIGURE 18 — y_{22} , OUTPUT-ADMITTANCE versus FREQUENCY

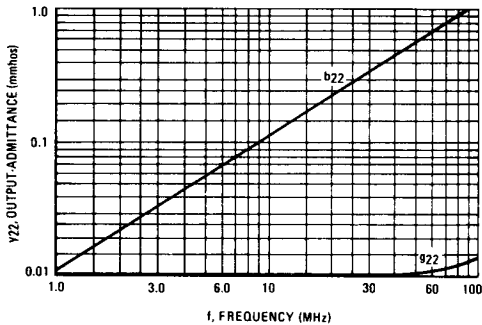

TYPICAL CHARACTERISTICS (continued)
 ($V_{CC} = 6.0$ Vdc, $T_A = +25^\circ\text{C}$ unless otherwise noted.)

FIGURE 20 – s_{11} , INPUT REFLECTION COEFFICIENT versus FREQUENCY

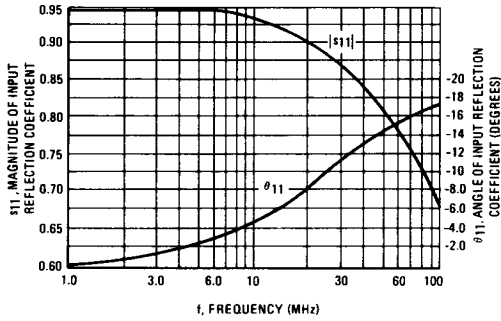

FIGURE 21 – s_{22} , OUTPUT REFLECTION COEFFICIENT versus FREQUENCY

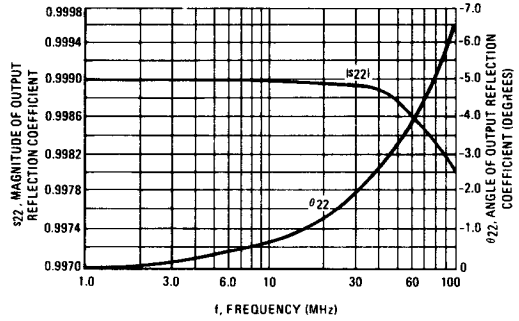

FIGURE 22 – s_{21} , FORWARD TRANSMISSION COEFFICIENT (GAIN)

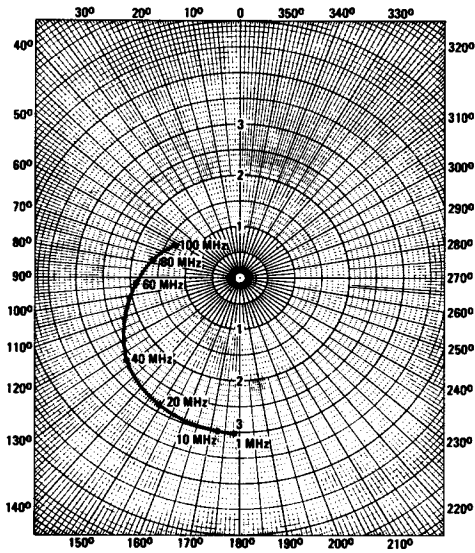

FIGURE 23 – s_{12} , REVERSE TRANSMISSION COEFFICIENT (FEEDBACK)

